



**2024**

**Technical  
Regulations**

# ROK CUP PNW TECHNICAL REGULATIONS 2024

## Table of Contents

### 1. ELIGIBLE KARTS AND EQUIPMENT

1.1 General	3
1.2 Classes Structure	3
1.3 Engines	3/4
1.4 Chassis	4/5/6
1.5 Tires	6
1.6 Oil	7
1.7 Fuel	7
1.8 Miscellaneous	7/8

### 2. TECHNICAL APPENDIX

MINI ROK	8/9
MICRO ROK	9
VLR ROK	9/10/11
VLR-JUNIOR ROK	11
ROK GP	11/12/13
ROK SHIFTER	13/14
VOLUME CHAMBER PROCEDURE CHECK	15
ENGINE DISTRIBUTION MEASURING	15/16
CLUTCH PROCEDURE CHECK	18
TECHNICAL OFFICER	18
TECHNICAL APPAREL	18/19
SUPPLEMENTALS	19



# 1. ELIGIBLE KARTS AND EQUIPMENT

## 1.1 General:

The Promoter reserves the right to make changes to the products provided to the Entrants such as, but not limited to oil, tires, fuel, etc. Any change will be communicated in advance, when possible or by the “Special Event Regulations.”

## 1.2 Classes Structure

Class	Age	Weight	Engine	Rear Width	Other
Micro ROK	7/10	245 lbs.	Mini ROK	MAX 1100mm	Same as Mini
Mini ROK	9/13	245 lbs.	Mini ROK	MAX 1100mm	
Junior ROK VLR	12/15	310 lbs.	ROK VLR	MAX 1400	Exhaust Restrictor.
Senior ROK VLR	15+	350 lbs.	ROK VLR	MAX 1400	
Master ROK VLR	32+	380 lbs.	ROK VLR	MAX 1400	
Junior ROK	12/15	320 lbs.	ROK GP	MAX 1400	Exhaust Restrictor.
Senior ROK	15+	375 lbs.	ROK GP	MAX 1400	
Master ROK	32+	400 lbs.	ROK GP	MAX 1400	
Shifter ROK Senior	15+	395 lbs.	ROK Shifter	MAX 1400	
Shifter ROK Master	32+	410 lbs.	ROK Shifter	MAX 1400	

## 1.3 Engines

**1.3.1** ROK Cup PNW is restricted to Vortex ROK engines (respecting the Homologation Fiche) **ONLY**. See only [www.ROKcupusa.com](http://www.ROKcupusa.com) for relative Homologations files.

**1.3.2** Engines **MUST** be run as supplied by the manufacturer. No modification or components substitution is allowed, unless otherwise specified in the “Special Event Regulations.”

**1.3.3** ROK Cup PNW Technical Officials have the right to inspect any engine or any part at any time during the Event and without any reason.

**1.3.4** ROK Cup PNW Technical Officials have the right to request, at any time during the Event and without any particular reason, to have competitors exchange parts of the engine (i.e. but not limited to clutch, exhaust, carburetor, coil, wiring loom, ignition, fuel, etc.) with an identical part provided free of charge by Vortex or ROK Cup Promotions LLC.

**1.3.5** Refusal to submit to inspection and/or exchange of parts, will result in disqualification from the Event.

**1.3.6** ROK Cup PNW Technical Officials have the right to request that the Drivers, at any time during the Event and without any reason, demonstrate on-board engine starting. **Not valid for ROK Shifter.**

**1.3.7** When engine sealing is declared for the Event, this must be done before qualifying.

**1.3.8** When engine sealing is not declared, conventional marking of engines will be done after qualifying.

**1.3.9** Each driver will be allowed to seal and use two engines per race beginning with the official qualifying session. Engine seal numbers must be entered by Entrant on **electronic or paper** Pre-Tech form **BEFORE** the start of qualifying and one engine must be sealed before qualifying, the other must be sealed before entering the grid.



**1.3.10** If engines need to be repaired the Entrant or his/her mechanic must take all necessary steps to replace damage parts, within the Tech Area and in presence of a Tech Official. In this instance, the Driver will retain his/her current position for the next competitive event.

**1.3.11** The Entrant, if they are unable to take all necessary steps to repair or replace damaged parts in the engine, will be allowed to replace the damaged engine with a new engine for competition. A “CHANGE OF MATERIAL” form must also be filled and presented to the Technical Director.

In the instance the Driver needs a *third* sealed engine, the Driver will be required to start from the back of the field during the next competitive event and both the original and replacement engines are subject to full technical inspection. The damaged engine must remain in the Technical Inspection area until released by the Technical Director.

**1.3.12** If the entrant is forced to use a third engine for the Event to improve performance: 1) the third engine must declared & sealed (if applicable), 2) their original engine must be left with ROK CUP Technical Director and both engines are subject to sealing & technical inspection, and 3) the competitor will start the next timed session or competitive event at the back of the field.

## **1.4** Chassis

**1.4.1** ROK Cup PNW is **OPEN** to any chassis with either the current CIK/FIA homologation or the CIK/FIA homologation of the previous period (including brakes and bodywork) and in compliance with the CIK/FIA Technical Regulations. Non-FIA homologated production chassis approved by ROK Cup USA for asphalt sprint racing are acceptable. Each Driver will be entitled to submit one (1) chassis for the event, changing chassis between drivers is forbidden. If a chassis (frame) is damaged beyond repair, as determined by a ROK CUP Official, an entrant can change chassis. The penalty will be starting from the back of their class Final event (regardless of when the chassis is damaged).

**1.4.2** The following parts **MUST** be safely secured with wire, circlips, snap ring, nylocks or metal lock nuts.

- Brake pedal to chassis.
- Brake rods (both ends).
- Master cylinder to chassis.
- Brake caliper to chassis spindle (Shifters **ONLY**).
- Brake calipers to spindle.
- Brake disc to brake hub (metal lock nuts only).
- Weights up to 5lbs single 8mm bolt; over 5lbs require two (2) 8mm bolts (must be double nutted), 35mm minimum diameter aluminum or steel washers should be utilized to prevent the seat from breaking. Weight must be white in color and must contain the kart number.
- Steering column to chassis.
- Steering wheel hub.
- Steering wheel hub to steering column.
- Tie rods at both ends.
- Kingpins.
- Spindle to wheels.
- Throttle pedal to chassis.

**1.4.3** Maximum diameter for rear axle is 50mm, 1.9 mm minimum thickness. Maximum diameter for Micro/Mini ROK rear axle is 30mm. Rear axle **MUST** be in magnetic steel.

**1.4.4** Bumpers are required front, rear, and side protection. Front and side bumpers **MUST** be made of magnetic steel, rear bumpers **MUST** be plastic. For all categories, they **MUST** be homologated with the bodyworks.

**1.4.5** The Floor Pan **MUST** be made of rigid material, and it must span from the central strut of the chassis frame to the front rail of the chassis frame. **MUST** be laterally edged to prevent the Driver's feet sliding off the floor pan. **ONLY** fixation holes allowed. **ONLY** one hole of maximum 35mm allowed for steering column access.

**1.4.6** Bodywork **MUST** have valid CIK/FIA homologation. Body work must be run as supplied, and in good



working condition no (holes, rips, tears) no modifications are allowed. Rear bumper minimum width (Mini 1040) (all others 1340). At no time shall the rear tire break the plain of the rear bumper.

**1.4.7** Transmission **MUST** be only to the rear wheels. Any kind of differential is prohibited.

**1.4.8** Chain guard is required. Full protection totally covering front and rear sprockets and chain is mandatory, **shifTERS require rear coverage**.

**1.4.9** Any kind of suspension device or suspension system is prohibited.

**1.4.10** Brakes must be current & valid CIK/FIA homologation or approved by major US karting sanctioning/safety bodies (a member of ACCUS, SFI, etc.).

**1.4.11** ShifTERS class: All shifter karts are required to have four-wheel braking with two (2) independent master cylinders.

**1.4.12** All single speed classes (Micro, Mini, VLR and GP) are permitted a single rear brake system only.

**1.4.13** Flexible duct tube(s) for brake cooling are permitted.

**1.4.14** Connection between brake pedal and master cylinder(s) must consist of both solid rod and safety cable with a minimum diameter of 1.8mm.

**1.4.15** Brake pedal, master cylinder and the brake caliper must be securely fixed to the frame.

**1.4.16** Carbon brake pads and/or brake disc are **NOT** allowed.

**1.4.17** Steering **MUST** be controlled by a steering wheel Steering Hub: Option 1-Standard hub (no angle), Option 2-One angled hub, Option 3-One standard hub with one angled spacer. Angles may not be achieved with washers.

**1.4.18** The main rim of the steering wheel **MUST** be steel or aluminum. Steering column **MUST** be magnetic steel.

**1.4.19** Seat **MUST** be designed to prevent the driver from moving to the sides or front when cornering or braking. Seats supports **MUST** be mounted by using nuts, bolts, and a metal or aluminum washer with a minimum diameter of 35mm and 1,5mm thickness to eliminate seat supports break through.

**1.4.20** Both pedals **MUST NOT** protrude forward of the chassis (including the bumpers) and **MUST** be mounted in front of the master cylinder. Brake pedal **MUST** have a double linkage to the master cylinder. Accelerator pedal **MUST** be equipped with a return spring.

**1.4.21** When chassis sealing is declared for the Event, this must be done before qualifying. When chassis sealing is not declared, conventional marking of chassis will be done after qualifying.

**1.4.22** It is forbidden to replace the chassis during the Event. Each Driver will be allowed to use one chassis per race. If the chassis is damaged beyond repair during the Event, the chassis may be replaced if and only if the ROK Cup USA Technical Officials check and provide their permission. A "CHANGE OF MATERIAL" form must also be filled and presented to the Technical Director.

**1.4.23** The replacement chassis **MUST** be of the same manufacturer and model.

### **Push Back Bumpers**

CIK Push Back Bumper Systems are required for all non-shifter classes.

Refer to the following FIA drawings for the technical specs of the Pushback Bumper System:

<https://backend.fiakarting.com/sites/default/files/2022-02/TD%203.2%20-%20Bodywork%20-%20Group%203.pdf>

The use of the following homologated items are mandatory for ROK Cup PNW Competition:

- Front Fairing must be a FIA Homologated Front Fairing
- Mounting Fairing Hardware must be a homologated front fairing mounting kit of the bodywork homologation period 2015 - 2024.

The front nose must be affixed to the kart with the CIK-stamped Front Fairing Mounting Kit, with the stamped arrow facing up. It must be possible for the front fairing to move freely back in the direction of the chassis without any obstruction from any part that may restrict movement. Any mechanical work or other intervention to maximize the friction of the front bumpers is strictly forbidden.

- Drivers must enter the official grid area with the front "PBB" fairing detached from their kart.



- The Driver, or mechanic, must attach the front “PBB” fairing without the use of tools and under the supervision of the ROK Cup PNW Grid Officials.
- Zip ties may be used to hold the clamp to the metal bumper portion but shall not hold the clamp from opening.
- The Grid Official has the right to inspect the front “PBB” fairing for modification or excessive wear and the compliance is determined by the ROK Cup PNW Officials.
- There must be a clearance at all points between the front bumpers, (upper and lower tubes), and the front fairing of 27mm, (1.063 inches) at all times.

The front fairing must be in the correct position at all times during competitive elements, (see [FIA Technical Drawing NO 3.2](#)). Should a driver or other person put back in place a front fairing that was not correctly positioned before the driver crosses the scales and reports to Tech, the driver will be disqualified from that competitive element.

### **CIK Push Back Bumper Penalties**

- The black flag with an orange disc **will not** be shown to a driver if a drivers front “PBB” fairing is no longer in the correct position.
- If the front “PBB” fairing is no longer in the correct position after the race with one side pushed in, a warning will be imposed automatically to the driver.
- If the front “PBB” fairing is no longer in the correct position after the race with both sides pushed in, a time penalty of **5 seconds** will be imposed automatically to the driver. The penalty may not be protested or appealed.
- The front fairing must be always in the correct position during competitive elements, (see CIK Technical drawings 2c and 2d). Should a driver or other person put back in place a front fairing that was not correctly positioned before the driver crosses the scales and reports to Tech, the driver **will be** disqualified from that competitive session.

## **1.5 Tires**

**1.5.1** ROK Cup USA is restricted to **LeVanto Tires ONLY**, unless otherwise indicated. The following tires are allowed:

Slick tires: LeVanto KRT 4,5/10,0 -5 + 7,1/11,0-5  
ROK Micro/Mini Rain tires: LeVanto KRT 4,0/10,0-5  
All Other Classes Rain tires: LeVanto KRT 4,0/10,0-5 +6,0/11,0-5

For reasons of unforeseen circumstances, at the sole discretion of ROK Cup Promotions LLC, a different brand, compound, or size of tire could be declared for a specific event and/or for a specific class.

**1.5.2** The maximum exterior diameter of the front wheel is 180mm. The maximum exterior diameter of the rear wheel is 300mm. The maximum width of the front wheel is 135mm. The maximum width of a rear wheel is 215mm. For Micro/Mini ROK class, the maximum exterior diameter of the front and rear wheels is 180mm and the maximum width of the front and rear wheels is 135mm.

**1.5.3** Any kind of tire treatment or modification is **FORBIDDEN**. Proof of treating a tire will result in immediate disqualification from the event and up to a one-year ban from all ROK Cup PNW events for driver, mechanic, and team principal. Heating or warming tires in the pits and/or pre grid is **FORBIDDEN**.

**1.5.4** Tampering with, deleting, covering, replacing and/or any modification to the tire’s barcode will result in a minimum of a one-year ban from entering and/or attending all ROK Cup USA events for driver, mechanic, and team principal.

**1.5.5** At the sole decision of the Race Director and/or ROK Cup Promotions, Tires Parc Fermè (Tire Farm) can be imposed.

**1.5.6** Drivers are forbidden from replacing tires during the Event. Tire allocations will be determined by the event organizer. These will be the only tires approved for the Event unless ROK Cup Promotions announces the



allowance of extra tires due for any reasons.

**1.5.7** All rain or dry tires must be submitted for marking and/or scanned at tire desk, if requested, and **ONLY** at designated time as per the event schedule and further announcements.

**1.5.8** All official event tires dry and wet must have bar codes.

## **1.6 Oil**

**1.6.1** Is restricted to Eni 2T two-cycle oil or Motul 2T two-cycle **ONLY**.

## **1.7 Fuel**

**1.7.1** Is restricted **UNLEADED ONLY**. In all instances the motor octane number must not exceed 110. No oxygenation additives or octane boosters are allowed. All fuel used at GMR, practice and race weekends, will be lead free as of July 1 2023.

**1.7.2** Fuel/oil is the **ONLY** combination allowed. **The spec ratio is one (1) Liter of oil for five (5) gallons of fuel for all classes.**

**1.7.3** ROK Cup PNW Technical Officials have the right to perform any kind of fuel tests to any competitor at any time during the Event and without any particular reason.

**1.7.4** Fuel test will be carried out by comparison. The Entrant will declare the type of percentage used if requested by ROK Cup PNW Technical Officials.

**1.7.5** Fuel Test Procedure will be determined by Technical Officials.

**1.7.6** Failure to pass fuel test will result in Event disqualification.

**1.7.7** Results of fuel tests are final.

**1.7.8** ROK Cup Promotions LLC reserves the right to prosecute to the full extent of the law any competitor found to be using any EPA---listed known cancer---causing products.

**1.7.9** Any driver, mechanic, and/or team principal caught using a fuel additive will receive an automatic one-year ban from all ROK Cup USA/PNW events. The proven use of any additive containing a known carcinogen can result in up to a *lifetime ban* from ROK Cup USA/PNW events and other series/sanctioning organizations who reciprocate/honor ROK Cup PNW's findings.

**1.7.10** At the sole decision of the Race Director and/or ROK Cup Promotions LLC, Fuel Parc Fermè can be imposed.

## **1.8 Miscellaneous**

**1.8.1** Composite materials are banned, except for the seat, floor pan and chain guard.

**1.8.2** Data acquisition devices capable of recording and displaying data **ONLY** are allowed.

**1.8.3** Any system capable of modifying fuel ratio mixtures, traction, throttle, ignition timing, etc. is forbidden.

**1.8.4** All drivers may utilize a maximum of two cameras. All cameras must be tethered, cannot be mounted higher than the steering wheel, cannot be mounted to helmets, side pods, front spoiler at any time. Cameras must be clearly marked with drivers name and contact phone number

**1.8.5** If the mounting of any device is considered dangerous by ROK Cup PNW Technical Officials, the ROK Cup PNW Technical Officials may request that such devices be removed.

**1.8.6** ROK Cup PNW is not responsible for any camera or other device that is lost on or off track.

**1.8.7** Communication between (to/from) Team & Driver and/or data acquisition devices via radio/telemetry or any other system is forbidden.

**1.8.8** No fluid spillage of any kind on the tarmac is allowed at any time. Catch bottles are highly recommended. Fluid spillage of any kind will result in a black flag.

**1.8.9** Transponders should be located as per CIK/ABM positioning: On back of seat at a height of 25cm +/- -- 5cm from tarmac, with no obstructions.

**1.8.10** Transponders will be MANDATORY as stated on the schedule. It is the responsibility of the Driver to ensure the transponder is properly mounted. If the transponder is not operable in any competitive session, the Driver will start from the rear of the field for the next competitive event.

**1.8.11** No lighting of any kind may be added to any kart for any official or unofficial on track session. The



illumination of any data screen must be as supplied by the manufacturer and may not be altered in any way.

**1.8.12 Numbers:** Racing numbers **MUST** be displayed on all four sides of the kart. Numbers **MUST** be easily readable and in block style. Yellow background and black number is highly recommended. ROK Cup USA officials have the right to require any competitor to change their number style, colors, and/or number at any time.

## **2. TECHNICAL APPENDIX**

### **MINI ROK**

#### **1. Fuel System:**

- a) All fuel system components must be utilized as supplied.
- b) No additional components are permitted.
- c) Any fuel filter, if utilized, must be placed between the fuel tank and the original fuel pump.

#### **2. Carburetor:**

- a) Tillotson HW-48A
- b) "ROK Engines" logo must be visible as laser-etched on rear face of carburetor (see "HW-48A\_Homologation 19.12.22.pdf")
- c) Stamped numbers on parts DO NOT guarantee the accuracy of the part.
- d) Refer to "HW-48A\_Homologation 19.12.22.pdf" for all technical measurements and part numbers.
- e) Refer to "Fiches MICRO, MINI ROK 2023.pdf" (pages 21-22) for information on intake manifold and intake manifold rubber mount.

#### **3. Air Box:**

- a. Foam air filter insert is optional.
- b. Air box clamps **MUST** be tight.
- c. Air box must not contain any additional holes.
- d. No external form of air ducts forcing air inside of air box is permitted.
- e. Air box must be secured completely after each track event otherwise last place position is given.
- f. Plastic protection under rain conditions is allowed.

#### **4. Coil:**

- a. Must be mounted to the engine.
- b. Must use coil wire as supplied.

#### **5. Wiring Harness:**

- a. Must use all components as supplied.
- b. No additional components are permitted.
- c. Must use original buttons.
- d. If any wire is damaged or cut, wire coupling can be used to repair cut wire area only.
- e. Replacing the ends of the harness is acceptable with similar part.
- f. Additional grounds are allowed.

#### **6. Battery:**

- a. Battery must be of the same physical dimensions as the supplied battery with kart number written on the battery.
- b. Battery must fit inside supplied battery box.
- c. Battery box must be attached to the frame with OEM attachments and at least one 175# tie-wrap.
- d. A secondary battery is allowed to power **only data systems, cameras, or transponder**.

#### **7. Spark Plug:**

- a. Only the following plugs allowed:





- i. NGK B/BR EG heat range is open.
    - ii. Must be original and no modification is allowed. (Changing the spark plug gap is allowed).
  - b. Original supplied spark plug washer or head temperature gauge sender must be in place.
  - c. Spark Plug Cap must be as supplied.
8. Exhaust Pipe:
  - a. No treatment of any kind.
  - b. No sand blasting is allowed.
  - c. No form of thermo wrapping is allowed.
  - d. Internal dimensions may not be altered because of rust.
  - e. No modifications to silencer end cap.
  - f. No major likings.
  - g. Exhaust temperature sensor:
    - i. One exhaust temperature sensor is allowed.
    - ii. One hole only can be drilled on the exhaust pipe for sensor.
    - iii. No specific location is required for the exhaust temperature sensor.
    - iv. Any hole not being used must be completely plugged if exhaust sensor is not being used.
    - v. Exhaust MUST remain intact, as provided by the manufacturer. No cracks and/or welding is permitted.
9. Exhaust Header:
  - a. As per Homologation File.
  - b. Headers cannot be cracked or leaking.
  - c. A go-no go gauge will be used to control headers. It is allowed to clean the restrictor headers with scotch-brite or solvent.
10. Clutch:
  - a. Clutch components MUST NOT contain significant amounts of any kind of oil or grease as determined by the opinion of the ROK Cup USA technical director and/or his designees.
  - b. It is mandatory to use the cover provided by Vortex Clutch Housing Plate (part #: W7000507300100).
11. Ignition Timing:
  - a. Standard (3mm.) +/-1 mm.
12. External Modifications:
  - a. Any modification clearly not called out inside this document is not to be taken as legally acceptable.
13. Chassis
  - a. Wheelbase 900mm or 950mm ONLY.
14. Vortex
  - a. Engine sprocket: Vortex 10T or 11T only.

## **MICRO ROK**

All rules, regulations, sizes and measures as per Mini ROK.

## **VLR ROK**

1. Fuel System:
  - a. All fuel system components must be utilized as supplied.
  - b. No additional components are permitted.
  - c. Any fuel filter must be fixed between the carburetor and the fuel tank, and no additional component are permitted.



2. Carburetor:
  - a. The only allowed carburetor is the Tillotson HW-38A.
  - b. Replacement parts must be of the same type and size as originally supplied.
3. Air Box:
  - a. Foam air filter insert is optional.
  - b. Air box clamps **MUST** be tight.
  - c. Air box must not contain any additional holes.
  - d. No external form of air ducts forcing air inside of air box is permitted.
  - e. Air box must be secured completely after each track event otherwise last place position is given.
  - f. Plastic protection under rain conditions is allowed.
4. Coil:
  - a. Must be mounted to the engine.
  - b. Must use coil wire as supplied.
5. Wiring Harness:
  - a. Must use all components as supplied.
  - b. No additional components are permitted.
  - c. Must use original buttons.
  - d. If any wire is damaged or cut, wire coupling can be used to repair cut wire area only.
  - e. Replacing the ends of the harness is acceptable with similar part.
  - f. Additional grounds are allowed.
6. Battery:
  - a. Battery must be of the same physical dimensions as the supplied battery with kart number written on the battery.
  - b. Battery must fit inside supplied battery box.
  - c. Battery box must be attached to the frame with OEM attachments and at least one 175# tie-wrap.
  - d. A secondary battery is allowed to power **only data systems, cameras, or transponder**.
7. Spark Plug:
  - a. Only the following plugs allowed:
    - i. NGK B/BR EG heat range is open.
    - ii. Must be original and no modification is allowed. (Changing the spark plug gap is allowed).
  - b. Original supplied spark plug washer or head temperature gauge sender must be in place.
  - c. Spark Plug Cap must be as supplied.
8. Exhaust Pipe:
  - a. No treatment of any kind.
  - b. No sand blasting is allowed.
  - c. No form of thermo wrapping is allowed.
  - d. Internal dimensions may not be altered because of rust.
  - e. No modifications to silencer end cap.
  - f. Exhaust temperature sensor:
    - i. One exhaust temperature sensor is allowed.
    - ii. One hole only can be drilled on the exhaust pipe for sensor.
    - iii. No specific location is required for the exhaust temperature sensor.
    - iv. Any hole not being used must be completely plugged if exhaust sensor is not being used.
    - v. Exhaust **MUST** remain intact, as provided by the manufacturer. No cracks and/or welding is permitted.
9. Exhaust Header:
  - a. As per Homologation File.
  - b. Headers cannot be cracked or leaking.
  - c. A go-no go gauge will be used to control headers. It is allowed to clean the



restrictor headers with scotch-brite and/or solvent.

**10. Clutch:**

- a. Clutch components **MUST NOT** contain significant amounts of any kind of oil or grease as determined by the opinion of the ROK Cup PNW technical director and/or his designees.
- b. It is mandatory to use the cover provided by Vortex Clutch Housing Plate (part #: W7000507300100).

**11. Ignition Timing:**

- a. Ignition timing non-tech.

**12. External Modifications:**

- a. Any modification clearly not called out inside this document is not to be taken as legally acceptable.

**13. Vortex**

- a. Engine sprocket: Vortex 10T, 11T, 12T, 13T.
- b. Cylinder base gasket thickness is non-tech and could be changed to adjust the port timing.
- c. Copper head gasket to adjust squish is allowed, thickness is non-tech.
- d. The shape of the combustion chamber must be original.

## **VLR JUNIOR ROK**

All rules, regulations, sizes and measures as per VLR ROK except for:

- 1. Exhaust:** Restrictor as per Homologation File.

## **ROK GP Junior – Senior – Master**

**1. Fuel System:**

- a. All fuel system components must be utilized as supplied.
- b. No additional components are permitted.
- c. Any fuel filter, if utilized, must be placed between the fuel tank and the original fuel pump.
- d. Vent tubes are optional, but fittings must remain in carburetor.
- e. Fuel Pump must be mounted to the engine.
- f. A plastic “Y” or “T” can be installed in the fuel line between the fuel pump and fuel inlet to the carburetor to facilitate the installation of a return line to the fuel tank. The “Y” or “T” must have the same inside diameters for all 3 connections.

**2. Carburetor:**

- a. Dell’Orto VSH 30.
- b. The only allowed changes to the Dell’Orto VSH 30 carburetor are main jet and needle clip position. Any other change or modification is not allowed.
- c. Carburetor airbox clamps must be used as supplied.
- d. Only OEM Dell’Orto parts are allowed and must be of the same type and size as originally supplied.
- e. All jets must be original Dell’Orto jets.
- f. Stamped numbers on parts **DO NOT** guarantee the accuracy of the part.
- g. Standard Dell’Orto VSH 30 Set Up:
  - Slide: #40
  - Needle: K33
  - Outer pilot: #60
  - Inner pilot: CD1 (B45 also allowed).
  - Emulsion tube: DP268
  - Floats: 4gm
  - Maximum venturi size: 30mm



### 3. Air Box

- a. Foam air filter insert is optional.
- b. Air box must not contain any additional holes.
- c. No external form of air ducts forcing air inside of air box is permitted.
- d. Air box must be secured completely after each track event otherwise last place position is given.
- e. Air box clamps **MUST** be tight.
- f. Unused end of carburetor socket may be trimmed away to where it intersects the slotted hub.
- g. Plastic protection under rain conditions is allowed.

### 4. Coil:

- a. Must be mounted to the engine.
- b. Must use coil wire as supplied.

### 5. Wiring Harness:

- a. Must use all components as supplied.
- b. No additional components are permitted.
- c. Must use original buttons.
- d. If any wire is damaged or cut, wire coupling can be used to repair cut wire area only.
- e. Replacing the ends of the harness is acceptable with similar part.
- f. Additional grounds are allowed

### 6. Battery:

- a. Battery must be of the same physical dimensions as the supplied battery with kart number written on the battery.
- b. Battery must fit inside supplied battery box.
- c. Battery box must be attached to the frame with OEM attachments and at least one 175# tie-wrap.
- d. A secondary battery is allowed to power **only data systems, cameras, or transponder.**

### 7. Spark Plug:

- a. Only the following plugs allowed:
  - i. NGK B/BR EG heat range is open.
  - ii. Must be original and no modification is allowed. (Changing the spark plug gap is allowed).
- b. Original supplied spark plug washer or head temperature gauge sender must be in place.
- c. Spark Plug Cap must be as supplied.

### 8. Exhaust Pipe:

- a. No treatment of any kind.
- b. No sand blasting is allowed.
- c. No form of thermo wrapping is allowed.
- d. Internal dimensions may not be altered because of rust.
- e. No modifications to silencer end cap.
- f. No major leaks.
- g. Exhaust temperature sensor:
  - i. One exhaust temperature sensor is allowed.
  - ii. One hole only can be drilled on the exhaust pipe for sensor.
  - iii. No specific location is required for the exhaust temperature sensor.
  - iv. Any hole not being used must be completely plugged if exhaust sensor is not being used.

### 9. Exhaust Header:

- a. As per Homologation File.
- b. Restrictor JUNIOR ROK as per Homologation File.
- c. Headers cannot be cracked or leaking.
- d. A go-no go gauge will be used to control restrictor headers. It is allowed to clean



the restrictor headers with scotch brite and solvents.

**10. Clutch:**

a. Clutch components MUST NOT contain significant amounts of any kind of oil or grease as determined by the opinion of the ROK Cup PNW technical director and/or his designees.

**11. It is mandatory to use the Vortex Clutch Housing Plate (part # W7000507300200) with the clutch.**

**12. Ignition Timing:**

a. Standard (3 mm.) +/-1 mm.

**13. External Modifications:**

a. Any modification clearly not called out inside this document is not to be taken as legally acceptable.

**14. Cooling System:**

a. Must be original as supplied.

i. Minor welding is allowed to cover up small holes.

ii. Additional metal mounting brackets may be used to secure Radiator.

iii. All radiators MUST be mounted on the left side of the driver and placed above the chassis frame. Supplementary radiators, if needed, may be mounted either on the left or right side.

b. Water hoses:

i. Original and after-market hoses are acceptable.

ii. It is not mandatory to use thermostat but if used must be OTK W866.

iii. If not using thermostat, only allowed split is for a water temperature sensor.

Water cooled engines will be allowed to use Hot Head water heating system

**15. Water Pump:**

a. ONLY one water pump may be used

b. External water pump MUST be located on the traverse tube of the chassis under the seat.

c. The water pump must be belt-driven by the axle, and may not be electrically powered in any way, shape, or form.

d. Non-Glycol additives are allowed for lubrication

**16. Reeds**

a. ONLY Vortex supplied reeds allowed.

**17. Power Valve:**

a. No-adjustable style only

b. Only new style short power valve caps are legal. Part#W10172/

## **ROK SHIFTER**

**1. Fuel System:**

a. All fuel system components must be utilized as supplied.

b. No additional components are permitted.

c. Any fuel filter, if utilized, must be placed between the fuel tank and the original fuel pump.

d. Vent tubes are optional, but fittings must remain in carburetor.

e. Fuel Pump must be mounted to the engine.

f. A plastic "Y" or "T" can be installed in the fuel line between the fuel pump and fuel inlet to the carburetor to facilitate the installation of a return line to the fuel tank. The "Y" or "T" must have the same inside diameters for all 3 connections.

**2. Carburetor:**

a. Dell'Orto VSHS 30

b. The only allowed changes to the Dell'Orto VSHS 30 carburetor are main jet and needle clip position. Any other change or modification is not allowed.

c. All original parts must be in the carburetor and remain stock.

d. Only OEM Dell'Orto parts are allowed and must be of the same type and size as originally supplied.



- e. Stamped numbers on parts DO NOT guarantee the accuracy of the part.
- f. Standard Dell'Orto VSH 30 Set Up:
  - Slide: #40
  - Needle: K98
  - Outer pilot: #60
  - Inner pilot: B45 (B46/47/48/49/50 also allowed)
  - Emulsion tube: ONLY DQ268
  - Floats: 4gm
  - Maximum venturi size: 30mm
  - 250 or 300 needle seat
- 3. Air Box
  - a. Foam air filter insert is optional.
  - b. Air box must not contain any additional holes.
  - c. No external form of air ducts forcing air inside of air box is permitted.
  - d. Air box must be secured completely after each track event otherwise last place position is given.
  - e. Air box clamps must be tight.
  - f. Plastic protection under rain conditions is allowed.
  - g. Unused end of carburetor socket may be trimmed away to where it intersects the slotted hub.
- 4. Coil:
  - a. Must be mounted to the engine.
  - b. Must use coil wire as supplied.
- 5. Spark Plug:
  - a. Only the following plugs allowed:
    - i. NGK B/BR EG heat range is open.
    - ii. Must be original and no modification is allowed. (Changing the spark plug gap is allowed).
  - b. Original supplied spark plug washer or head temperature gauge sender must be in place.
  - c. Spark Plug Cap must be as supplied.
- 6. Exhaust Pipe:
  - a. No treatment of any kind.
  - b. No sand blasting is allowed.
  - c. No form of thermo wrapping is allowed.
  - d. Internal dimensions may not be altered because of rust.
  - e. No major leaking.
  - f. Exhaust temperature sensor:
    - i. One exhaust temperature sensor is allowed.
    - ii. One hole only can be drilled on the exhaust pipe for sensor.
    - iii. No specific location is required for the exhaust temperature sensor.
    - iv. Any hole not being used must be completely plugged if exhaust sensor is not being used.
- 7. Exhaust Silencer:
  - a. No treatment of any kind.
  - b. No sand blasting is allowed.
  - c. No form of thermo wrapping is allowed.
  - d. Internal dimensions may not be altered because of rust.
  - e. Cannot be cracked or leaking.
  - f. **Factory size and packing material must be in place and in good condition. No other material or amount of packing is permitted.**

8. Ignition Timing:
  - a. Standard (1,5mm.) +/-1 mm.
9. External Modifications:
  - a. Any modification clearly not called out inside this document is not to be taken as legally acceptable.
10. Cooling System:
  - a. Radiator height maximum 50cm from the top of the Radiator excluding the cap and overflow hose to the track service.
  - b. Water hoses:
  - c. Original and after market hoses are acceptable.
  - d. Non Glycol additives are allowed for lubrication.

Water cooled engines will be allowed to use HotHead water heating system
11. Water Pump:
  - a. ONLY one water pump may be used.
  - b. External water pump MUST be located on the traverse tube of the chassis under the seat.
  - c. The water pump must be belt-driven by the axle, and may not be electrically powered in any way, shape, or form.
12. Engine Mount:
  - a. The engine mount for the shifter does not have to be as supplied, but it must be of similar dimensions, construction, and material as the supplied motor mount.
15. Reeds
  - a. ONLY Vortex supplied reeds allowed.

## PROCEDURE FOR CHECKING THE COMBUSTION CHAMBER VOLUME

### (CC) PROCEDURE

1. Have the engine disassembled from the chassis; unless otherwise directed by technical director
2. Wait until the engine is at ambient temperature (obligation for the organizer to supply special cooling fans);
3. Remove the spark plug (check the 18.5mm dimension)
4. Insert a certified CIK CC tool in place of the spark plug, the insert must be fixed on the head in the same way as the 18.5 mm spark plug.
5. Place the piston at the top dead center
6. Make sure the engine is level
7. With a laboratory burette with graduated scale (mechanical grade A or electronic) fill the combustion chamber with OIL type: "**MARVEL MISTERY OIL**", until the liquid verges on the upper edge of the insert.
8. The volume measured then must be that established by Vortex engine Fiche
9. In case of discrepancy of the measured value, the procedure will be conducted one additional time

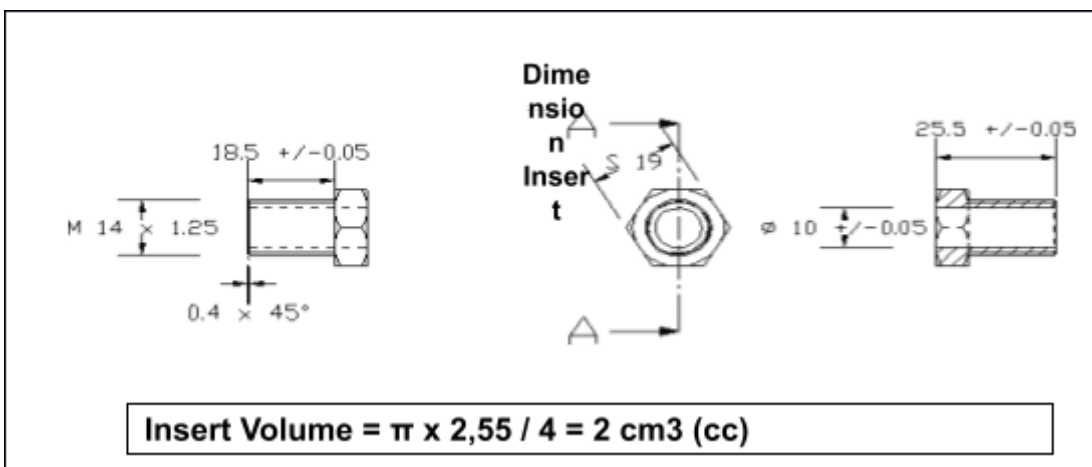

## SQUICH PROCEDURE

1. Remove the spark plug
2. Use approved solder (Kester, Solid Core Part#14-5050-062 1.5mm)
3. Insert solider parallel to the wrist pin, must touch the cylinder wall
4. Roll the engine by hand over top dead center to squish solider
5. Measure solider with digital caliper
6. The volume measured then must be that established by Vortex engine Fiche
7. In case of discrepancy of the measured value, the same procedure will be conducted one additional time, on the side directly opposite of the first procedure
8. The average of both sides will determine final measurement.

## ENGINE DISTRIBUTION MEASURING GAUGE.

For all ROK categories where control is foreseen, the angle of discharge, suction, decanting and jumping must be measured with a thickness of 0.20 mm, having a width of 5 mm (as per drawing).

The reading is performed using a digital display with an encoder measuring device, or with a graduated disk with a minimum diameter of 200 mm.

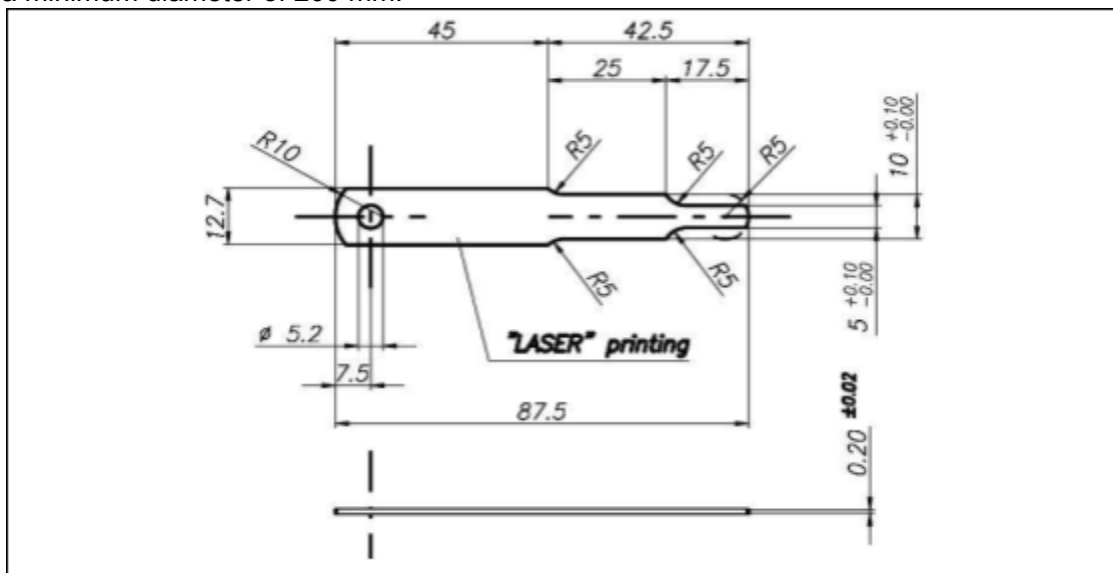



## MINI ROK ENGINE INTAKE GAP CONTROL

<p>TURN CLOCKWISE AND LIFT THE PISTON TO ALLOW THE INSERTION OF THE FEELER GAUGE AGAINST THE LOWER EXHAUST EDGE.</p>	<p>TURN COUNTERCLOCKWISE AND LOWER THE PISTON UNTIL IT MEETS THE GAUGE RESTING AT THE EXHAUST EDGE, AT THIS STAGE SET THE SCALE ON THE POSITION OF 0 DEGREES.</p>
<p>RELEASE THE FEELER GAUGE AND TURNING COUNTERCLOCKWISE LOWER THE PISTON TO ALLOW THE INSERTION OF THE FEELER UNDER THE UPPER EDGE OF THE EXHAUST.</p>	<p>TURN CLOCKWISE TO LIFT THE PISTON UNTIL IT MEETS THE FEELER GAUGE RESTING AT THE EXHAUST EDGE. AT THIS STAGE CHECK THAT THE EDGE OF DISPLACEMENTS OF THE VERNIER MATCH NOT LESS THAN <b>31 DEGREES</b>.</p>

## VLR PORT GAUGE

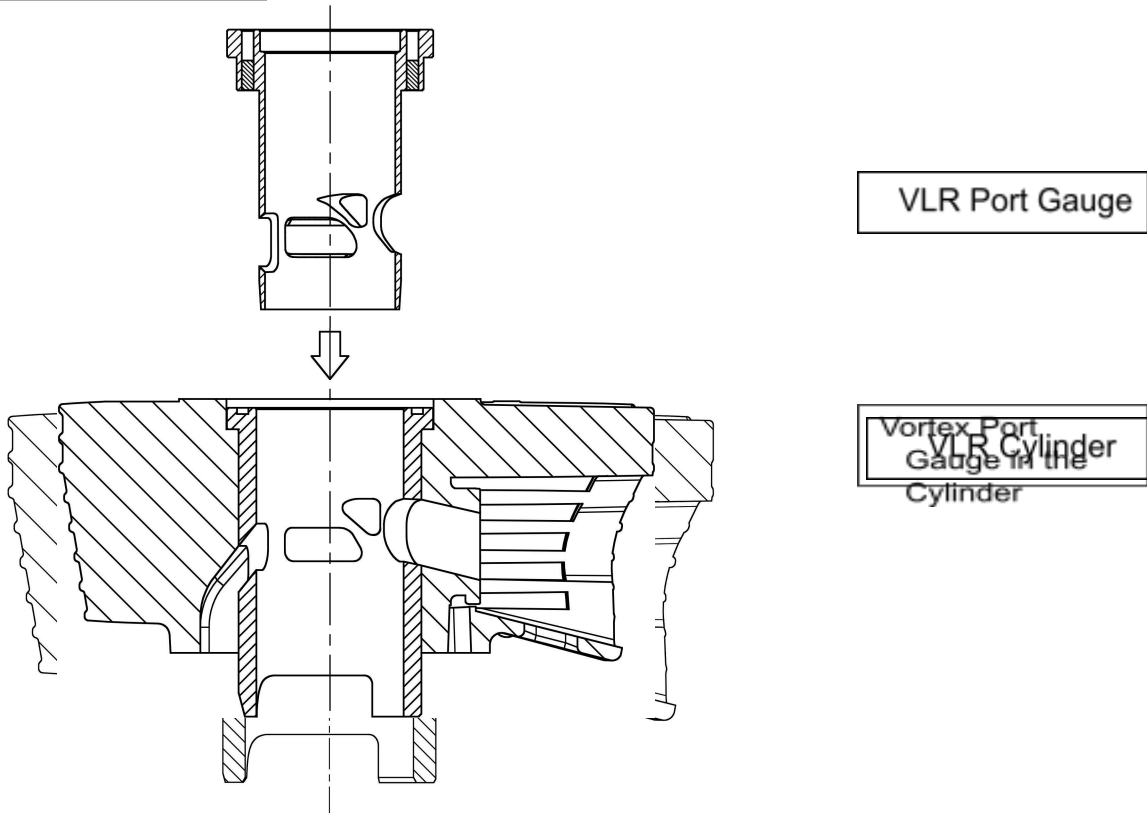

By inserting the reference port gauge in the cylinder, after having positioned it correctly, the Technical Officer will be able, at the technical scrutineering, to detect any irregularities.

## CLUTCH TECHNICAL CONTROL

The following clutch controls are allowed for all motorized classes with **ROK GP** engines:

- from a standstill in the pre-race and at the end of the race, in order to check the first advance of the clutch at 4000rpm (after checking the overall mass); the clutch must be in direct drive at 100% at the minimum of 5000 rpm in all conditions.

The following clutch controls are allowed for all motorized classes with **VLR ROK** engines:

- from a standstill in the pre-race and at the end of the race, in order to check the first advance of the clutch at 3500rpm (after checking the overall mass); the clutch must be in direct drive at 100% at the minimum of 4000 rpm in all conditions.

The following clutch controls are allowed for all motorized classes with **MICRO and MINI ROK** engines:

- from a standstill in the pre-race and at the end of the race, in order to check the first advance of the clutch at 3500rpm (after checking the overall mass); the clutch must be in direct drive at 100% at the minimum of 4000 rpm in all conditions.

## TECHNICAL OFFICIER

The technical procedures for checking the engine and / or any other detail must be carried out only by Race



Officials designated by **ROK CUP PNW** for the event, in compliance with what is indicated in the TECHNICAL RULE BOOK; for any complaints and / or appeals we refer to what is indicated in this regard by the SPORTING RULE LS BOOK.

## **TECHNICAL APPAREL**

1. All safety apparel must be worn as the manufacturer intended and designed to be worn.
2. ONLY helmets with the following minimum standards are allowed:
  - FIA Helmets (all helmets expire 10 years after manufactured date and/or 10 years after spec -whichever is first):
    - FIA 8860-2018
    - FIA 8860-2018 APB
    - FIA 8859-2015
    - FIA 8860-2010
  - SNELL Helmets:
    - M or SA 2014 (expires 12/31/2025)
    - CMR or CMS 2016 Youth (expires 12/31/2026)
    - K, M, or SA 2020 (expires 12/31/2030)
  - SFI Helmets:
    - SFI 41.1/2013 (expires 12/31/2023)
    - SFI 24.1/2015 Youth (expires 12/31/2025)
    - SFI 31.1 or 41.1/2015 (expires 12/31/2025)
    - SFI 24.1/2021 Youth (expires 12/31/2030)
3. Racing Suits Overalls: mandatory, with a current CIK/FIA or SFI valid homologation ONLY.
4. Gloves: for racing purposes with a high degree of abrasion resistance.
5. Footwear: MUST cover full ankle and MUST be designed and manufactured for racing purposes.
6. Neck Protection: mandatory for Micro ROK, Mini ROK and Junior ROK. Loss or lack of neck protection during practice, qualification, heats, pre-final, and/or final will result in a black flag.
7. Chest Protection is required for all drivers in Micro/Mini classes and Junior classes if the driver is 13 years of age or younger. It is highly recommended for drivers in all classes. SFI, CIK, or FIA certification is required.
8. Hair cannot be visible outside of the helmet. It is the driver's responsibility to secure/hide long hair in a safe manner. Any driver with visible hair that could become a danger to themselves, or others will be black flagged immediately; this is non-protetable. ROK Cup Promotions is not liable or responsible for injuries related to long hair while on-track, regardless of the situation.



## **SUPPLEMENTALS:**

**1.1** 1 Only 1 set of Levanto rains/Dry tyres for double header weekend.

### ENGINE LINKS:

- <https://rokcupusa.com/wp-content/uploads/2024/04/Fiche-ROK-MINI-MICRO-2024-USA.pdf>
- <https://rokcupusa.com/wp-content/uploads/2024/04/Fiche-ROK-VLR-2024-USA.pdf>
- [https://rokcupusa.com/wp-content/uploads/2023/05/Fiche-rok-gp-gpjr-2023\\_USA\\_5-9-2023.pdf](https://rokcupusa.com/wp-content/uploads/2023/05/Fiche-rok-gp-gpjr-2023_USA_5-9-2023.pdf)
- [https://rokcupusa.com/wp-content/uploads/2023/05/Fiches-Rok-SHF-2023\\_USA\\_5-9-2023.pdf](https://rokcupusa.com/wp-content/uploads/2023/05/Fiches-Rok-SHF-2023_USA_5-9-2023.pdf)

### **MUST READ WCKC CLUB SUPPLEMENTALS AND CLUB RULES FOR 2024 SEASON :**

- [https://static1.squarespace.com/static/65d132f1ac618355e7635efc/t/666b51c86a7f965410996e84/1718309320687/WCKC\\_Weights\\_And\\_Classes\\_2024\\_Rev\\_04-16-2024b.pdf](https://static1.squarespace.com/static/65d132f1ac618355e7635efc/t/666b51c86a7f965410996e84/1718309320687/WCKC_Weights_And_Classes_2024_Rev_04-16-2024b.pdf)
- [https://static1.squarespace.com/static/65d132f1ac618355e7635efc/t/65f136b35efa6257af78676b/1710306995551/WCKC\\_2024\\_General\\_Club\\_Rules\\_Ver\\_03-11-2024.pdf](https://static1.squarespace.com/static/65d132f1ac618355e7635efc/t/65f136b35efa6257af78676b/1710306995551/WCKC_2024_General_Club_Rules_Ver_03-11-2024.pdf)

(( These documents can be found as well : <https://www.westcoastkartclub.ca/rules> ))